



DPM2

Optical DisplayPort Extension system

Customer :

Specification for

Model : DPM2

Revised : November 5, 2015
Original Release Date : July 1, 2014

OPHIT

Revision History

Version Number	Revision Date	Author	Description of Changes
0.1	July 1, 2014	H.S YANG	Initial Version
0.2	November 24, 2014	H.S YANG	Electrical Specification modified
1.0	February 4, 2015	H.S YANG	Initial Version (Production Version)
1.1	May 8, 2015	H.S YANG	Optical Spec Added.
1.2	June 16, 2015	H.S YANG	Receiver Connector Pin Assignment modified.
			Reach DOC Added.
1.3	November 5, 2015	H.S YANG	Electrical Specification modified

TABLE OF CONTENTS

1. General Description

2. General Specification

3. Absolute Maximum Ratings

4. Electrical Specification

4.1 Electrical Specification

4.1.1 Transmitter(Source) Module

4.1.2 Receiver(Sink) Module

4.2 Optical Specification

4.2.1 Transmitter Characteristics

4.2.2 Receiver Characteristics

4.3 Connector Pin Assignment

5. Mechanical Specification

5.1 Case Dimension

5.2 Cable Information

5.2.1 Electric Cable

5.2.2 Optical Cable

6. RoHS

6.1 ROHS2 DOC

6.2 REACH DOC

1. General Description

DPM2, This fiber optic cable system let your DisplayPort compliant display device extend up to 40 meters (131.2 fit) away from host based on DisplayPort standard without signal degradation by 4K UHD (3840 x 2160 @ 60Hz) resolution.

- High speed and long distance transmission by optical system
- compatible with DisplayPortV1.2a standard by VESA
- The use of standard DisplayPort source-sink connector
- MMF optical fiber + copper hybrid cable structure
- HBR2(High Bit Rate) Cable Assembly (up to 5.4Gbs Data Rate)
- AUX and Hot Plug channels are transmitted by copper line
- DPCD/HDCP compliant
- Power operation LED installed
- Gender or signal conversion equipment does not guarantee
- Internal source power supply need for proper operation
- Dual mode is not support.

2. General Specification

Parameter	Symbol	
	Transmitter	Receiver
Optical Converter	4 ch 850nm Multi-mode VCSEL	4 ch GaAs PIN photo Diode
Input and Output Signal	DisplayPort Signal (Std. V1.2a)	
Video Bandwidth	4 lanes, 21.6 Gbps(HBR2)	
Module Size	114 x 25 x 21mm (WxDxH)	114 x 25 x 21mm (WxDxH)
Using electrical connector	20 pin DisplayPort Plug(Male)	20 pin DisplayPort Plug(male)
Applied Fiber	50/125 μ m Multi-mode glass-fiber	

3. Absolute Maximum Ratings

Parameter	Rating
Storage temperature	-20°C ~ +70°C
Operating temperature	0°C ~ +50°C
Power Supply(DC)	-0.3 ~ +3.3V
Relative Humidity	10 ~ 80 %
Lead solder temperature	260°C, 10 seconds

NOTICE

Stresses greater than those listed under “Absolute Maximum Ratings” may cause permanent damage to the device. This is a stress rating only and functional operation of the device at these or any other conditions above those indicated in the operations section for extended periods of time may affect reliability.

4. Electrical Specification

4.1 Electrical Specification

4.1.1 Transmitter (Source) Module

Parameter		Symbol	Min	Typ	Max	Units	Condition
P O W E R	Supply Voltage(DC)	Vcc	+2.9	+3.3	+3.6	V	
	Supply Current	Icc		0.18		A	4K 60Hz(MST)
	Power Dissipation	Po		0.59		W	
S I G N A L	Diff. P-to-P Input level 1	VTX-DIFF-PP1	0.34	0.4	0.46	V	
	Diff. P-to-P Input level 2	VTX-DIFF-PP2	0.51	0.6	0.68	V	
	Diff. P-to-P Input level 3	VTX-DIFF-PP3	0.69	0.8	0.92	V	
	Diff. P-to-P Input level 4	VTX-DIFF-PP4	1.02	1.2	1.38	V	
	TX DC Common Mode	VTX-DC-CM	0		2.0	V	
	TX AC Common Mode HBR2	VTX-AC-CM			30	mV rms	

Transmitter module of Model DPM2 includes 4 channel VCSEL(Vertical Surface Emitting Laser Diode) with 850 nm invisible laser radiation.

Transmitter module of DPM2 is Class 1 Laser Product.

4.1.2 Receiver(Sink) Module

Parameter		Symbol	Min	Typ	Max	Units	Condition
P O W E R	Supply Voltage	Vcc	+2.9	+3.3	+3.6	V	
	Supply Current	Icc		0.21		A	4K 60 Hz(MST)
	Power Dissipation	Po		0.69		W	
S i g n a l	Diff. P-to-P Output Voltage	T _{RX-DIFFp-p_HBR2}	70			mV	For HBR2
	Diff. P-to-P Output Voltage	V _{RX-DIFFr-p}	40			mV	For RBR
	RX DC Common Mode	V _{RX-DC-CM}	0		2.0	V	

4.2 Optical Specification

4.2.1 Transmitter Characteristics

Parameters	Symbol	Specified			Unit	Test Conditions
		Min.	Typ.	Max.		
Peak Fiber Coupled Optical Output Power	P_{oc}		0.500		μW	If = 6 mA, 50/125 μm fiber NA=0.20
Threshold Current	I _{th}		1.0	2.0	mA	CW
I _{th} Temperature Variation	ΔI_{th}		1.0		mA	T _a =-10 to 85 oC
Slope Efficiency	H	0.04		0.16	W/A	If = 6 mA
η Temperature Variation	$\Delta \eta / \Delta T$		-4000		PPM/ oC	T _a =-10 to 85 °C at 6 mA
Coupling efficiency	EFCE		75		%	If = 6 mA
Peak Wavelength	λP	840	850	860	nm	If = 6 mA
λP Temperature Coefficient	$\Delta \lambda / \Delta T$		0.06		nm/ oC	T _a =-10 to 85 °C at 6mA
Spectral Bandwidth (RMS)	$\Delta \lambda$		0.4		nm	If = 6 mA
Forward Voltage	V _f		2.2	2.5	V	If = 6 mA
Breakdown Voltage	V _b		-10		V	I _r = 10 μA
Small Signal Bandwidth	GHz	8				If = 6 mA
Rise and Fall Times	t _R		40		ps	Prebias Above Threshold, 20%~80%
	t _F		50			
Relative Intensity Noise	RIN			-130	dB/Hz	10GHz BW, If = 6mA
Series Resistance	RS		80		Ohm	If = 6 mA
Rs Temperature Coefficient	dRs/dT		-2000		PPM/ oC	

Parameters	Symbol	Specified			Unit	Test Conditions
		Min.	Typ.	Max.		
Monitor Current	IPD	0.2		0.7	mA	POC=0.5mW
Dark current	ID			10	nA	Po=0mW, Vr=3V
PD Reverse Voltage	BVRPD	40			V	Po=0mW,Ir=100mA
PD Capacitance	C			50	pF	Vr=0V,Freq=1MHz
				20		Vr=3V,Freq=1MHz

4.2.1 Receiver Characteristics

Parameters	Symbol	Specified			Unit	Test Conditions
		Min.	Typ.	Max.		
Sensitivity	S	-12	-14		dBm	BER=1E10-12 PRBS=231-1 at 10.3125Gbps
Optical Overload	OL		0		dBm	
Differential Saturated Output Swing	Vout-,diff	240	280	350	mVp-p	
3dB Bandwidth	fh,-3dB	7	10		GHz	Pave=-12dBm, λ =850nm, referenced to 100MHz
Low Frequency Cutoff	LF		30	100	KHz	
Wavelength responsivity	λ	830	850	860	nm	
Rise/Fall Time	tR/tF			50	ps	Pave=-12dBm, λ =850nm
Output Resistance	Ro	30	50	60	Ω	
Monitor Current Slope vs IIN	I MON-P		0.5			
Monitor Current Offset	I OFFSET		10		μ A	no photo current
Monitor Current linearity	I RANGE	1		1100	μ A	

4.3 Connector Pin Assignment

Transmitter (Source, Male)

Pin	Signal Assignment	Pin	Signal Assignment
1	Main Link Lane 0 (Positive)	11	Ground
2	Ground	12	Main Link Lane 3 (Negative)
3	Main Link Lane 0 (Negative)	13	Config1 (Ground)
4	Main Link Lane 1 (Positive)	14	Config2 (Ground)
5	Ground	15	AUX Channel (Positive)
6	Main Link Lane 1 (Negative)	16	Ground
7	Main Link Lane 2 (Positive)	17	AUX Channel (Negative)
8	Ground	18	Hot Plug
9	Main Link Lane 2 (Negative)	19	Return
10	Main Link Lane 3 (Positive)	20	DP_PWR (+3.3V input)

Receiver (Sink, Female)

Pin	Signal Assignment	Pin	Signal Assignment
1	Main Link Lane 3 (Negative)	11	Ground
2	Ground	12	Main Link Lane 0 (Positive)
3	Main Link Lane 3 (Positive)	13	Config1 (Ground)
4	Main Link Lane 2 (Negative)	14	Config2 (Ground)
5	Ground	15	AUX Channel (Positive)
6	Main Link Lane 2 (Positive)	16	Ground
7	Main Link Lane 1 (Negative)	17	AUX Channel (Negative)
8	Ground	18	Hot Plug
9	Main Link Lane 1 (Positive)	19	Return
10	Main Link Lane 0 (Negative)	20	Not Connect(DP_PWR)

5. Mechanical Specification

5.1 Case Dimension

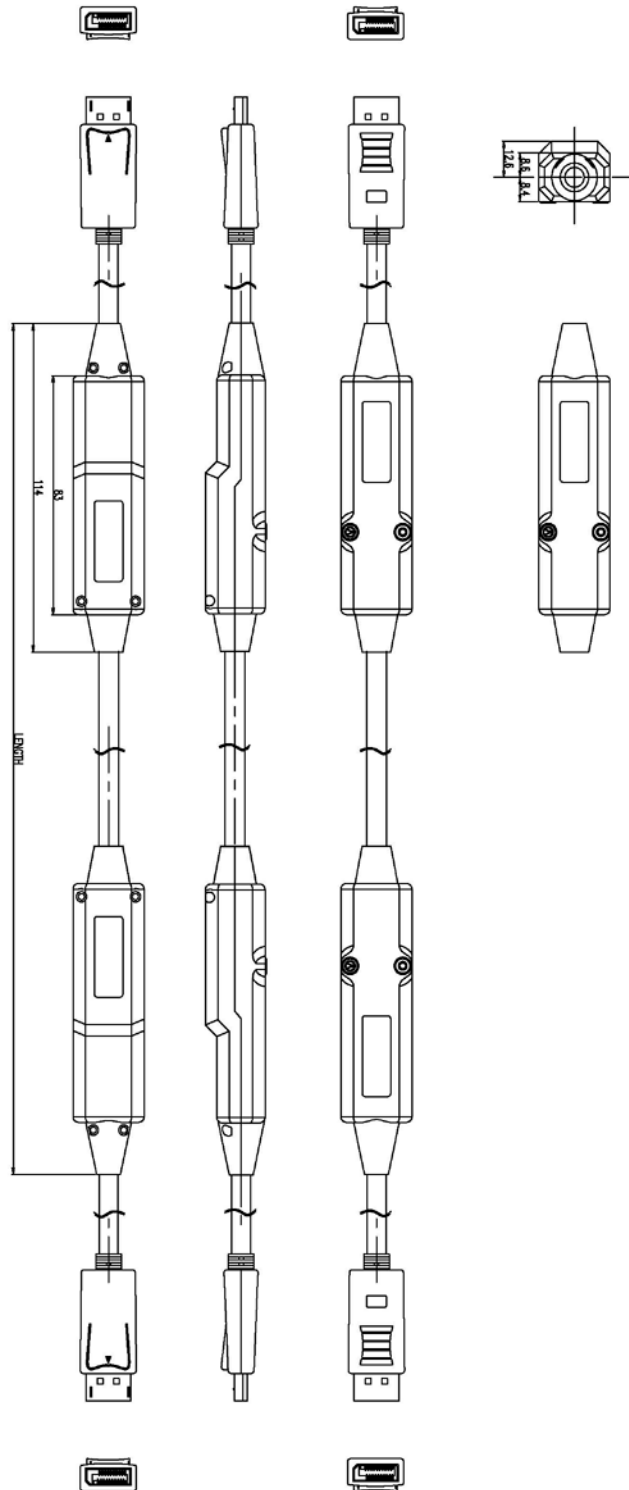

5.2 Cable Information

5.2.1 Copper Cable Information

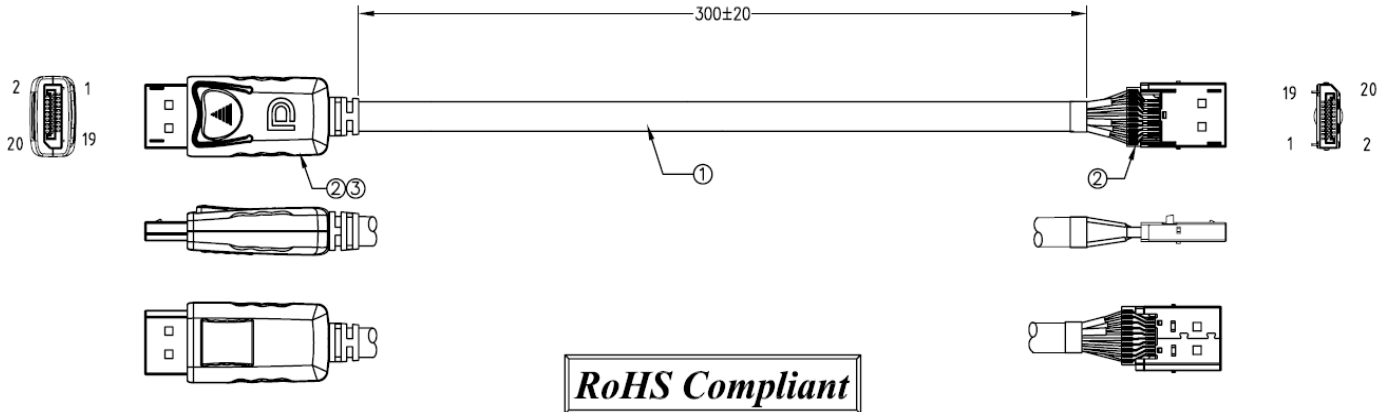

3	INNERMOLD	PE LOW DENSITY
2	CONNECTOR	DISPLAYPORT PLUG CONTACT: 15u" SHELL: G/F W/LATCH W/COVER BLACK
1	CABLE	Display Port CABLE UL20276 30AWG OD: 6.0 BLACK
NO.	PART NAME	SPEC DESCRIPTION

PIN ASSIGNMENT:

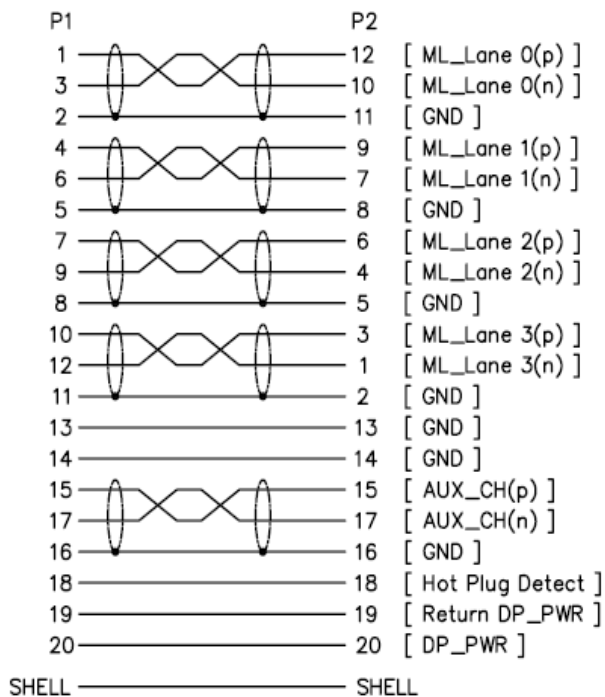

Electrical character:

- a. 100% open & short testing.
- b. Withstanding voltage: DC 300V 0.01Sec.
- c. Insulation resistance: 10M Ohm(Min.).
- d. Conductive resistance: 3 Ohm(Max.).

5.2.2 Optical Cable Information

The construction of 4 optical fibers and 6 copper wires cable shall be in accordance with Figure 1 and Table 1.

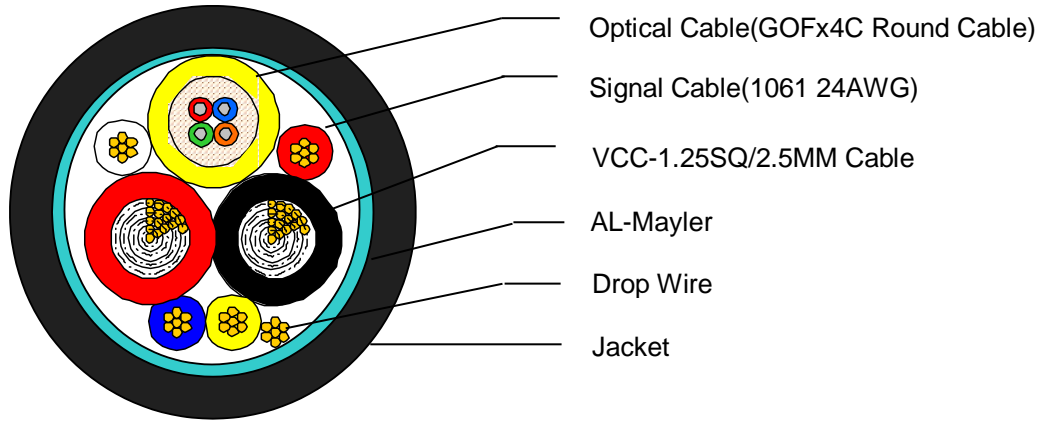

Figure 1. Cable structure of DPM2

Table 1. Specification of electrical wire for DPM2 cable

The Dimension of DPM2 Cable		
Items	Unit	Specification
DVI Cable Make-up	-	Layer Stranding
Drain Wires (Size/Stranded)	mm(AWG)	-0.203/7 (24)
AL-Mylar Screen Shield	-	A helically
Cable Outer Diameter	mm	7.40±0.20
Jacket Color	-	FR-PVC(Orange, Blue, Black)
Cable Marking	-	If need

The construction of 4 optical fibers and 4 copper wires cable shall be in accordance with Figure 2 and Table 2 and 3.

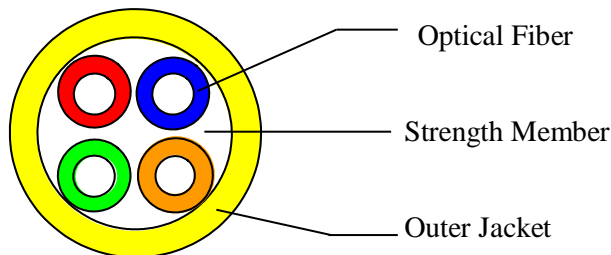

Figure 2. Cable structure of GOFx4C Round Cable

Table 2. Fiber Cable Construction

Item		Description
Optical Fiber	Number	4
	Structure	Figure 1
Strength Member		Aramid Yarn
Outer Jacket	Material	FR-PVC(Yellow)
	Approx. Thickness	1.6mm
Nominal Outside Diameter		$\phi 4.0 \pm 0.4 \text{mm}$
Approximate Net Weight		10kg/km
Cable Identification		OPTICAL CABLE

Table 3. Fiber Cable Characteristics

Item	spec.	unit	Condition
Storage Temperature	-40 ~ 70	°C	Spooled
Operational Test	-20 ~ 70	°C	-
Max. Tensile Load	245	N	By careless handling(short term)
Min. Radius Bend	75	mm	By careless handling(short term)
	125		After installing(long term)
Crush Resistance	490	N/50mm	By careless handling(short term)

6. ROHS

6.1 ROHS2 DOC



Declaration of RoHS Compliance

DIRECTIVE 2002/95/EC OF THE EUROPEAN PARLIAMENT AND OF THE COUNCIL OF 27 January 2003 on the restriction of the use of certain hazardous substances in electrical and electronic equipment

Product Name : DPM2

Hereby we guarantee that we do not intentionally use the substances described below and based on third party chemical analysis the thresholds of the substances as indicated are not exceeded for our products.

Banned Substances by RoHS Directive 2011/65/EU, EN50581:2012

Substance	RoHS Limity by Weight	RoHS Limity by % (PPM)
Lead (Pb)	1000mg/kg	0.1% (1000 PPM)
Mercury (Hg)	1000mg/kg	0.1% (1000 PPM)
Hexavalent Chromium (CR VI)	1000mg/kg	0.1% (1000 PPM)
Polybrominated Biphenyls (PBB)	1000mg/kg	0.1% (1000 PPM)
Polybrominated Diphenyl Ethers (PBDE)	1000mg/kg	0.1% (1000 PPM)
Cadmium (Cd)	100mg/kg	0.01% (100 PPM)

Signature : Jong-kook Moon *Jong-kook Moon*

Title : CEO

OPHIT CO.,LTD.
 3F, Suntechnovil, 5-27 Mangpo-Dong,
 Yeongtong-Gu, Suwon-City, Gyeonggi-Do, Korea

6.2 REACH DOC



**EUROPEAN UNION'S REACH REGULATION
DECLARATION CERTIFICATE**

The European REACH Regulation 1907/2006 on Registration, Evaluation, Authorization, and Restriction of Chemicals(REACH), Annex XVII entered into Force in June 2009, and affects all companies producing, Importing, using, or placing Products on the European market. The aim of the REACH regulation is to ensure a high Level of protection of human health and the environment from chemical substances.

OPHIT Co., Ltd substances management system follow and complies with the current revision of the REACH Regulation on the substances as identified by ECHA(European Chemical Agency).

OPHIT Co., Ltd products are considered articles as defined in REACH Article 3(3). These products/articles under normal and reasonable conditions of use do not have intended release of substances. Therefore the requirement in REACH Article 7(1)(b) for registration of substances contained in these products/articles does not apply.

OPHIT Co., Ltd products/articles, do not contain **Substances of very High Concern** or if there **SVHC** in the product/article, the content is less than the 0.1%(wt/wt) as defined by REACH Article 57, Annex XIV, Directive 67/548/EEC. Therefore the requirement in REACH Article 7(2) to notify ECHA if a product/article contains more than 0.1% wt/wt of an SVHC and tonnage exceeding 1 tone per importer per year is not applicable.

OPHIT's European operations do not manufacture or import chemicals, therefore OPHIT Co., Ltd has no obligation to resister substances.

-Model : DPM2

Jong-kook, Moon

Jong-Kook, Moon
President

OPHIT Co., Ltd ACCEPTS NO DUTY TO NOTIFY USERS OF THIS OF DECLARATION OF UPDATES OR CHANGES TO THIS DECLARATION.

CONTACT INFORMATION
 Name : Eui-Seok, Kang / OPHIT Co., Ltd
 Title : Q.A Deputy Manager
 Tel : +82-31-205-4191
 E-mail : onlyqa@ophit.com